

▶ ▶ ▶ **DURAHOIST™**

**PRODUCT INFORMATION**

**Miller DuraHoist™ four piece confined space system.**

The four piece Miller DuraHoist system is designed for manhole and confined space entry/retrieval applications.

The modular design allows for the use of components in various configurations and applications. Multiple winches and/or self retracting lifeline systems may be mounted as required.

DuraHoist™ is constructed from lightweight high strength powder-coated aluminum, no tools are required for assembly.

**PRODUCT FEATURES**

- ⇒ Lightweight, easy storage, transport and set-up.
- ⇒ Height of mast can be adjusted according to users requirements.
- ⇒ DH-4 has built-in level indicator for easy levelling.
- ⇒ Quick release joins for easy collapsibility and transport.
- ⇒ Three piece base features adjustable screws for easy set-up.

**APPLICATIONS**

- ⇒ Confined Space
- ⇒ Rescue

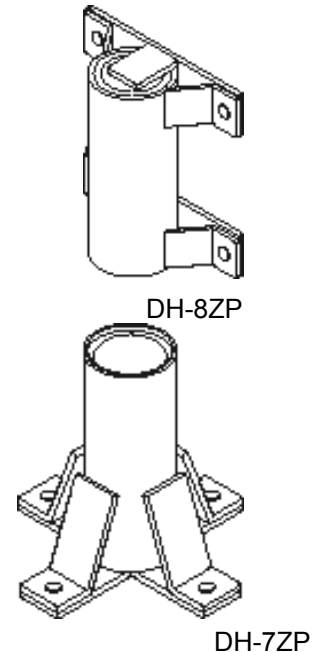

**TECHNICAL INFORMATION**

- ⇒ DH-3 mast has 2272kg capacity fall arrest anchor point.

**MOUNTING SLEEVES**

- ⇒ A wide variety of mounting sleeves are available with the DuraHoist range.
- ⇒ DH-7ZP is a floor mount sleeve which is suitable for mounting on horizontal structures.
- ⇒ DH-8ZP is a wall mount sleeve which is suitable for mounting on vertical structures.

**ORDERING & PACKAGING INFORMATION**

Part Number	Description	Weight	Cat	Min Order	Product Dimensions
DH-3	One Piece Adjustable Mast	13kg	B	1	See specification sheet
DH-4	Three Piece Portable Base	28kg	B	1	See specification sheet
DH-7ZP	Floor Mount Sleeve	5.9kg	B		See specification sheet
DH-8ZP	Wall Mount Sleeve	5.5kg	B	1	See specification sheet

**WARNING!** THIS DOCUMENT PROVIDES AN OVERVIEW OF PERSONAL PROTECTIVE PRODUCTS AVAILABLE FROM SPERIAN PROTECTION AND CARE HAS BEEN TAKEN TO ASSURE THE ACCURACY OF THE DATA. IT DOES NOT PROVIDE IMPORTANT PRODUCT WARNINGS AND INSTRUCTIONS. SPERIAN PROTECTION RECOMMENDS ALL USERS OF ANY PERSONAL PROTECTIVE EQUIPMENT UNDERGO THOROUGH TRAINING, AND THAT ALL WARNINGS AND INSTRUCTIONS PROVIDED WITH THE PRODUCTS BE THOROUGHLY READ AND UNDERSTOOD PRIOR TO EACH USE. FAILURE TO READ AND FOLLOW ALL PRODUCT WARNINGS AND INSTRUCTIONS COULD RESULT IN SERIOUS INJURY.

▶ ▶ ▶ **DURAHOIST™**

**PRODUCT INFORMATION**

**Miller DuraHoist™ fall arrest anchor post, rescue davit and materials handling arm.**

The Miller DuraHoist portable fall arrest anchor post has been designed for use on top of transformers or other types of vertical platforms. The fall arrest anchor post provides three independent swivel tie-off points for fall-arrest anchorage and a three stage/four position telescoping design. Components are constructed of lightweight high strength aluminium for ease of storage, transport, set-up and manageability. The levelling screws allow the system to be plumbed to vertical for better working stability on inclines up to 15°. The anchor post also provides Horizontal Lifeline (HLL) capabilities using the HLL anchor ring. The anchor post collapses into one single piece weighing only 17.5kg.

**PRODUCT FEATURES**

- ⇒ DH-AP-1 has three stage, four position telescoping design and aluminium construction for easy transportation and setup.
- ⇒ Can be installed for vertical applications or on inclines of up to 15°.
- ⇒ DH-AP-3 Rescue Davit Arm can be used with the portable fall arrest anchor post.
- ⇒ Quick-attach design addresses materials handling or rescue needs.



DH-AP-1



DH-AP-3

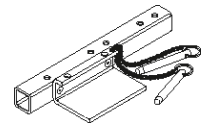

DH-19-MILLER

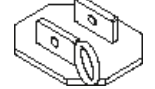

DH-AP-4

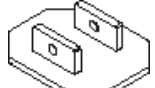

DH-AP-5

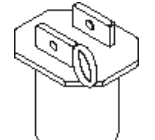

DH-AP-6

**ANCHOR PLATES**

DuraHoist anchor plates are designed for welding to existing structures and locations of frequent work.

- ⇒ DH-AP-4 includes a tie-off anchorage point.
- ⇒ DH-AP-5 is a standard anchor plate.
- ⇒ DH-AP-6 includes a tie-off anchor point for inclined surfaces.
- ⇒ DH-19-MILLER adapter bracket for mounting the Miller MightyEvac™ and/or Miller ManHandler™ onto a DuraHoist System.

**APPLICATIONS**

- ⇒ Construction
- ⇒ Vertical Platforms

**ORDERING & PACKAGING INFORMATION**

Part Number	Description
DH-AP-1	Portable Fall Arrest Anchor Post
DH-AP-3	Rescue Davit Arm
DH-AP-4	Plate with tie off adaptor
DH-AP-5	Standard Plate
DH-AP-6	Anchor Plate for inclined surface
DH-19-MILLER	Adaptor Bracket

**WARNING!** THIS DOCUMENT PROVIDES AN OVERVIEW OF PERSONAL PROTECTIVE PRODUCTS AVAILABLE FROM SPERIAN PROTECTION AND CARE HAS BEEN TAKEN TO ASSURE THE ACCURACY OF THE DATA. IT DOES NOT PROVIDE IMPORTANT PRODUCT WARNINGS AND INSTRUCTIONS. SPERIAN PROTECTION RECOMMENDS ALL USERS OF ANY PERSONAL PROTECTIVE EQUIPMENT UNDERGO THOROUGH TRAINING, AND THAT ALL WARNINGS AND INSTRUCTIONS PROVIDED WITH THE PRODUCTS BE THOROUGHLY READ AND UNDERSTOOD PRIOR TO EACH USE. FAILURE TO READ AND FOLLOW ALL PRODUCT WARNINGS AND INSTRUCTIONS COULD RESULT IN SERIOUS INJURY.