

New!

MILLER

DURAHOIST™

CONFINED SPACE SYSTEM

*COMPLETE &
ECONOMICAL
CONFINED
SPACE SYSTEMS*

*Lightweight &
Portable!*



MILLER®

New!

MILLER

DURAHOIST™

Lightweight, portable unit weighing only 91lbs (without the winch).

Constructed of lightweight high-strength aluminum.

Davit pivots for ease of rescue and adjusts for overhead clearance.

Base adjusts to fit most standard entries. Other bases are available.



DH-1

Miller DuraHoist Confined Space System		
Model No.	Description	Weight
DH-1	Four Piece Hoist System w/50 ft. Winch, P#:#: DH50S/50FT	113 lbs (41.2 kg)

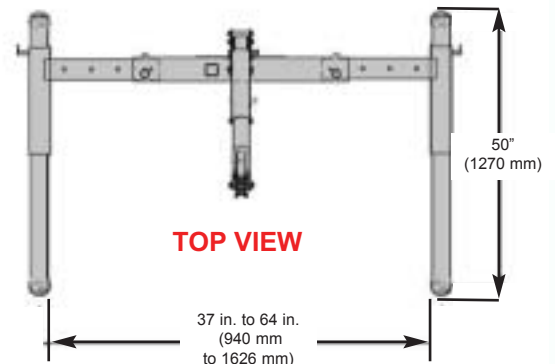
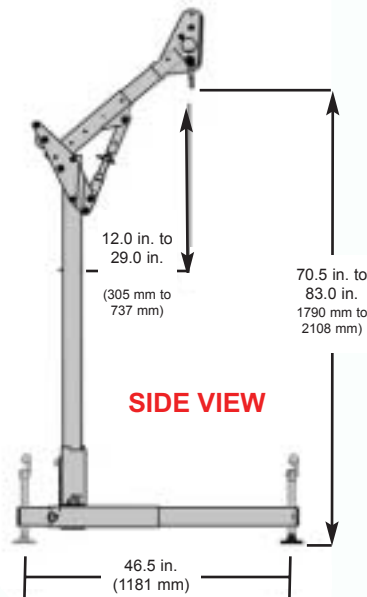

ON THE COVER: DH-2 shown with optional MightEvac (MR50GB/50FT), Series 100 Digital Winch (DH100/70FT) and wheel kit (DH4-VWK).

INSET: DH-AP-1 shown with optional Rescue Davit Arm (DH-AP-3) and 14" Extension Post (DH-AP-4). Additional information about these options can be found later in this catalog.

Four Piece DuraHoist System

The **Four Piece DuraHoist System** is designed for manhole and confined space entry/retrieval applications. The modular design allows the use of components in various configurations and applications. Multiple winches and/or lifeline systems may be mounted as required. Lightweight, manageable components for easy storage, transport and set-up. No tools required for assembly.

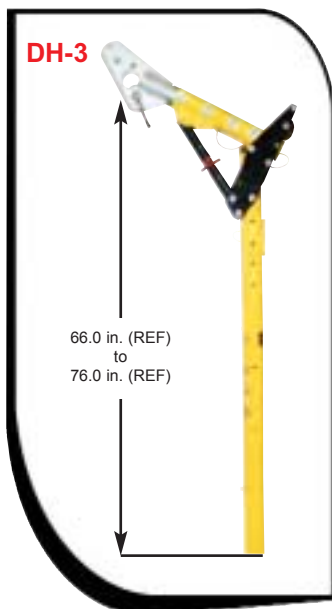

One Piece Adjustable Mast

The **One Piece Adjustable Mast** is designed for use where multiple offset masts are required. It can be combined with lower masts, mast extensions and bases and may be equipped with front mounted and/or back mounted winches & self retracting lifelines. The DH-3 features a 5000lb (2272 Kg) capacity anchor point for fall-arrest anchorage. The adjustable height of the mast can eliminate the need for custom length masts and mast extensions for applications with overhead clearance restrictions. The quick-release pin allows easy collapsibility and transport. The DH-3 features powder-coated aluminum construction for lightweight durability.

Three Piece Portable Base

The **Three Piece Portable Base** is constructed of lightweight powder-coated aluminum and features adjustable aluminum screws & a built-in level indicator for easy set-up on un-even surfaces. Three lightweight components for easy transport and storage. No tools required for assembly. *See page 11 for carrying bag options.*

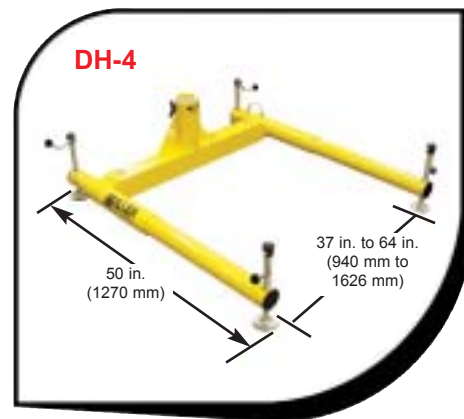

Miller DuraHoist Confined Space System & Accessories		
Model No.	Description	Weight
DH-3	One Piece Adjustable Mast	31 lbs (14.1 kg)
DH-4	Three Piece Portable Base for Max. 30 in. Offset	60 lbs (27.3 kg)

Miller DuraHoist Portable & Fixed Bases

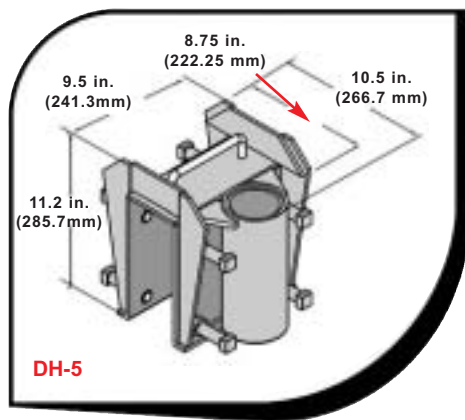

Barrel Mount Sleeve w/ 3.5 in. Opening features mild steel construction. Eight independent clamping screws allow temporary installations over edges of shoring cans, walls and other structures. Includes PVC inner liner.

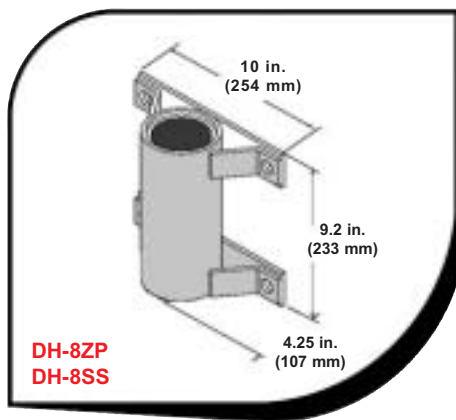

The **Wall Mount Sleeve** features CS-500 zinc-plated mild steel construction or 304 stainless steel construction. Compact design creates minimum intrusion into work space. Mounts to vertical concrete or steel structures. Includes PVC sleeve liner.

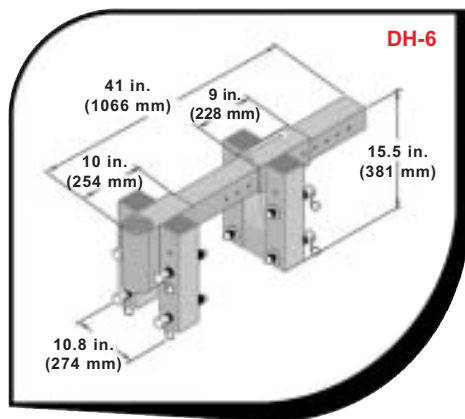

Adjustable Barrel Mount Sleeve is designed for shoring, wall & parapet applications where frequent set-up over varying wall thicknesses is required. Accommodates wall thicknesses up to a max. of 24 in., with shorter or longer adjustment tubes available on request. Anodized, welded aluminum with zinc plated steel hardware for lightweight durability. Includes inner sleeve.

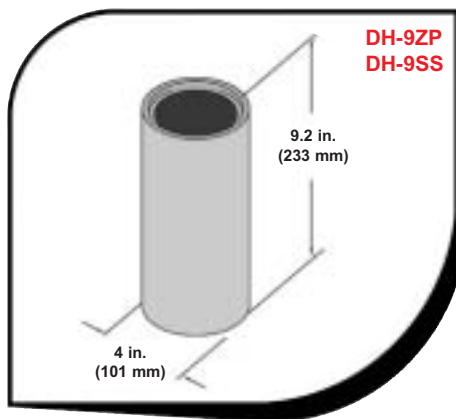

The **Core Mount Sleeve** is designed for slip-in installation into 4"Ø core hole in concrete or in an existing steel structure. Includes PVC sleeve liner. Available in CS-500 Zinc-plating or 304 Stainless Steel.

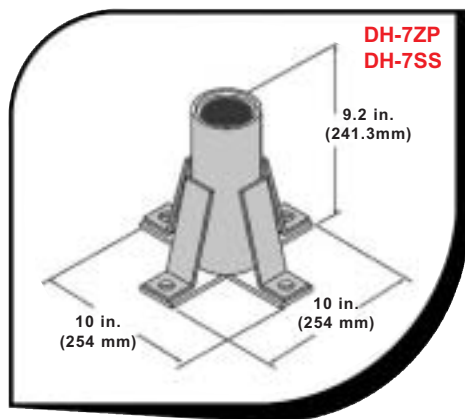

The **Floor Mount Sleeve** mounts to horizontal concrete or steel structures. Available with CS-500 Zinc plating or with a 304 Stainless Steel finish. Both models include a PVC liner.

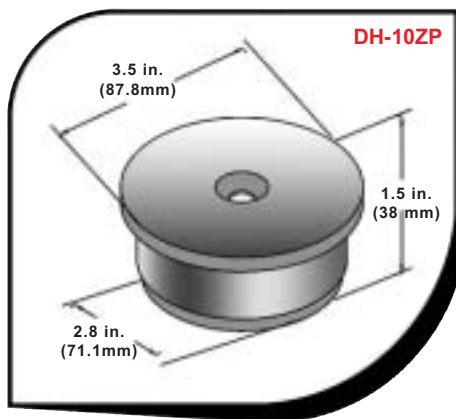

The **Sleeve Cap** is made of heavy duty-mild steel or stainless steel construction. Keeps dirt and debris from getting into the opening of various sleeve mounts when not in use.

Miller DuraHoist Confined Space System & Accessories

Model #	Description	Weight
DH-5	Barrel Mount Sleeve with 3.5 in. Opening	36.5 lbs (16.6 kg)
DH-6	Adjustable Barrel Mount Sleeve	56 lbs (25.5 kg)
DH-7ZP	Floor Mount Sleeve, CS-500 Zinc-plated, Mild Steel	13 lbs (5.9 kg)
DH-7SS	Floor Mount Sleeve, 304 Stainless Steel	13 lbs (5.9 kg)
DH-8ZP	Wall Mount Sleeve, CS-500 Zinc-plated, Mild Steel	12 lbs (5.5 kg)
DH-8SS	Wall Mount Sleeve, 304 Stainless Steel	12 lbs (5.5 kg)
DH-9ZP	Core Mount Sleeve, CS-500 Zinc-plated, Mild Steel	8 lbs (3.6 kg)
DH-9SS	Core Mount Sleeve, 304 Stainless Steel	8 lbs (3.6 kg)
DH-10ZP	Sleeve Cap, CS-500 Zinc-plated, Mild Steel	0.8 lbs (0.36 kg)
DH-10SS	Sleeve Cap, 304 Stainless Steel	0.4 lbs (0.2 kg)

Miller DuraHoist Manhole Collars

Manhole Collars are designed for applications involving frequent setups over similarly sized access openings. Simply slip collar into sewer manhole, tank hatch or other openings. Lightweight, powder-coated aluminum construction for portability. Includes PVC sleeve liner.



Miller Portable Manhole Collars		
Model No.	Description	Weight
DH-11/17.5	17.5 in. Manhole Collar for use with 18 in. - 20 in. dia. manways	26 lbs (11.7 kg)
DH-11/19.5	19.5 in. Manhole Collar for use with 20 in. - 22 in. dia. manways	29.5 lbs (13.3 kg)
DH-11/21.5	21.5 in. Manhole Collar for use with 22 in. - 24 in. dia. manways	33.5 lbs (15.1 kg)
DH-11/23.5	23.5 in. Manhole Collar for use with 24 in. - 26 in. dia. manways	38 lbs (17.2 kg)
DH-11/25.5	25.5 in. Manhole Collar for use with 26 in. - 28 in. dia. manways	43 lbs (19.5 kg)
DH-11/27.5	27.5 in. Manhole Collar for use with 28 in. - 30 in. dia. manways	48 lbs (21.7 kg)

Note: Measurements are taken from the inside of the manhole.

Miller DuraHoist Vehicle Hitch Mount Sleeve

The **Vehicle Hitch Mount Sleeve** is designed to install into a 2 inch hitch receiver on an attendant vehicle to provide a portable anchor point for confined space entry/retrieval, rescue and fall-arrest systems. Various sockets, extensions and accessories are available for use with the sleeve.



DH-13 The Multi-Directional Bumper Receiver installs between the standard model DH-12 Hitch Mount Sleeve or Hitch Mount Extension and the attendant vehicle to compensate for uneven on-site ground conditions. The 2 inch Ball Hitch Adapter and Pintle Hitch Adapters are available for use with the sleeve. All hitch options are CS-500 zinc-plated for corrosion resistance.

Miller Vehicle Hitch Mount Sleeve		
Model No.	Description	Weight
DH-12	Vehicle Hitch Mount Sleeve	49 lbs (22.2 kg)
DH-13	Vehicle Hitch Mount 2-Foot Extensions	17 lbs (7.7 kg)
DH-14	Universal Joint Assembly	8.5 (3.9 kg)
DH-15	Pintle Hitch Adapter	13 lbs (5.8 kg)
DH-16	2 inch. Ball Hitch Adapter	19 lbs (8.6 kg)
DH-17	Single Direction Bumper Receiver	7.8 lbs (3.5 kg)

Miller DuraHoist Portable Fall-Arrest Anchor Post

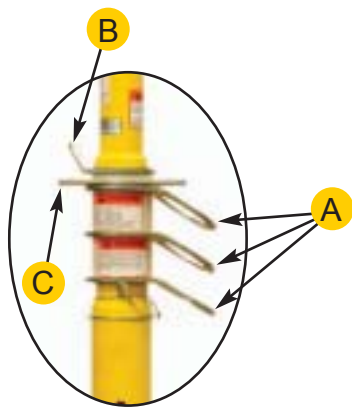

Tie-Off Anchor Components

- A - Swivel Tie-Off Ring (3)
- B - Swivel Davit Anchor
- C - Horizontal Lifeline (HLL) Anchor Ring

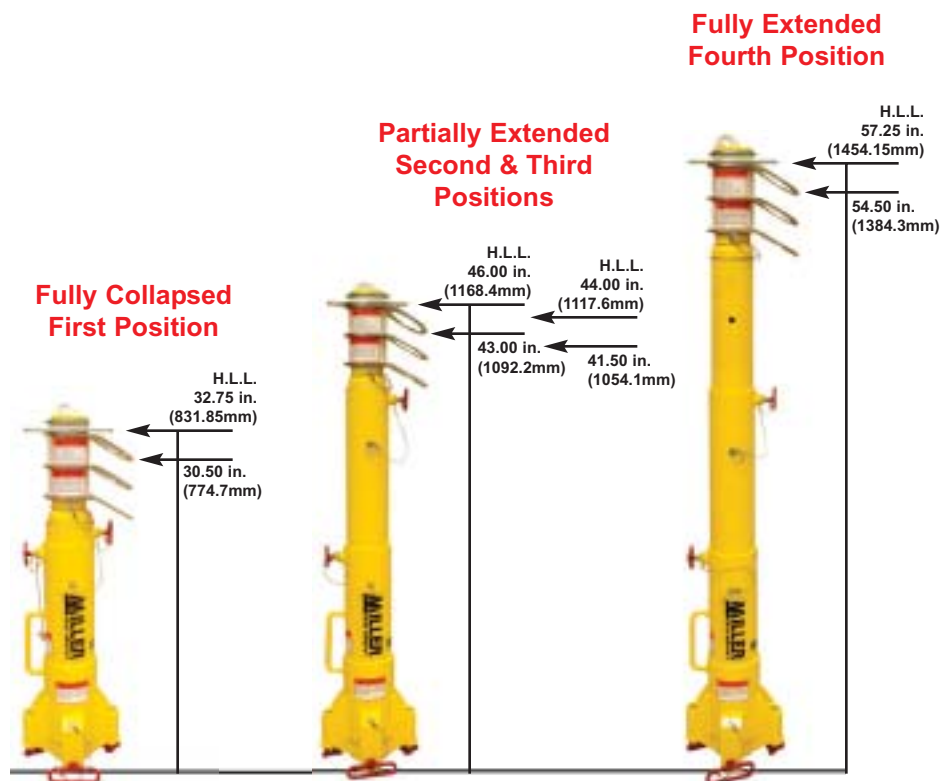

The Miller DuraHoist Portable Fall-Arrest Anchor Post provides three independent swivel tie-off points for fall-arrest anchorage*, three stage/four position telescoping design and aluminum construction for easy transportation and setup. The leveling screws allow the system to be plumbed to vertical for proper working stability on inclines up to 15°. The anchor post also provides Horizontal Lifeline (HLL) capabilities using the HLL Anchor Ring. The anchor post collapses into one single piece weighting only 38 lbs (17.5 kg) and fits into a single padded carrying bag for transport and storage of components (see the back page for available carrying bags).

*A maximum of 3 workers may be anchored to the Portable Fall-Arrest Anchor Post at any given time with any MILLER DuraHoist approved accessories. Refer to specification sheets for complete dimensions, proper use and installations.

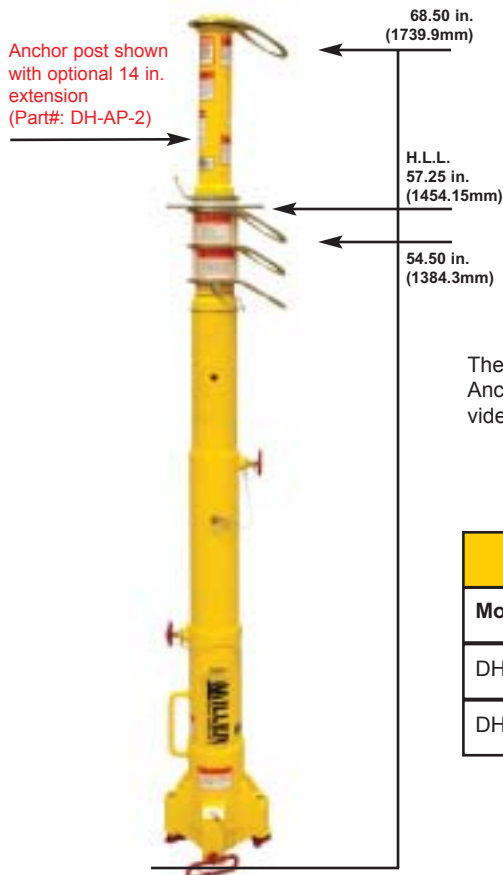

The Anchor Post Extension is designed for use with the Portable Fall-Arrest Anchor Post (Part # DH-AP-1). This extension weighs only 5 lbs (2.2 kg) and provides the option to tie-off one worker at an increased height of 68.50 inches.

Miller DuraHoist Portable Fall-Arrest Anchor Post		
Model No.	Description	Weight
DH-AP-1	Portable Fall-Arrest Anchor Post	38 lbs (17.5 kg)
DH-AP-2	14" Extension Post	5 lbs (2.2 kg)

Miller DuraHoist Portable Fall-Arrest Davit Arm & Anchor Plates

The **Rescue Davit Arm & Material Handling** option is to be used with the **Miller DuraHoist Portable Fall-Arrest Anchor Post** (Part # DH-AP-1) and related accessories. Lightweight aluminum construction makes it easy to transport and set-up. The quick-attach design assembles easily to address material handling or rescue needs.

Note: Rescue Davit Arm works in the 2nd and 4th positions only. A maximum of 3 workers may be anchored to the Portable Fall-Arrest Anchor Post at any given time with any MILLER DuraHoist approved accessories. Refer to specification sheets for complete dimensions, proper use and installations.

Miller DuraHoist Portable Fall-Arrest Anchor Post		
Model No.	Description	Weight
DH-AP-3	Rescue Davit Arm	20.5 lbs (9.2 kg)

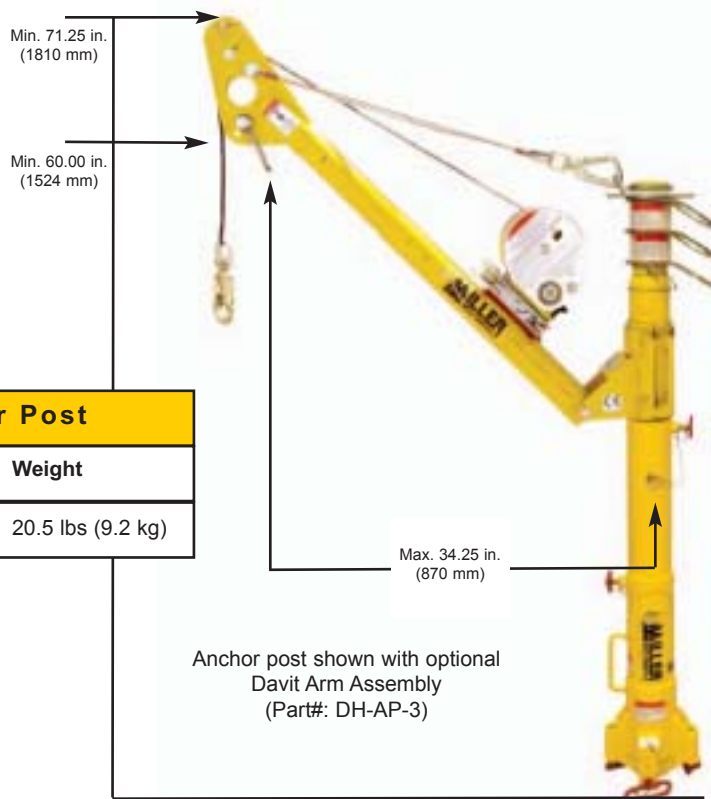

Anchor post shown with optional Davit Arm Assembly (Part#: DH-AP-3)

Miller Anchor Plates

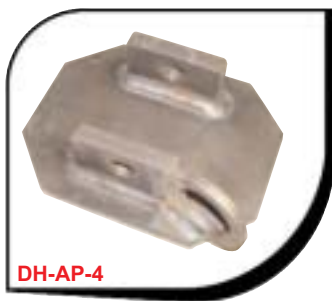

DH-AP-4



DH-AP-5



DH-AP-6



DH-AP-7

DuraHoist Anchor Plates are designed to be permanently welded to existing structures in locations of frequent work, or where the use of a portable base is impractical. Several different anchor plates are available to meet your safety needs. The **DH-AP-4** and **DH-AP-6** provide tie-off anchors, while the **DH-AP-7** and **DH-AP-6** can be customized to your specific incline requirements up to a maximum of 45 degrees.

Miller DuraHoist Portable Fall-Arrest Post Anchor Plates		
Model No.	Description	Weight
DH-AP-4	Plate with tie-off anchor	11.6 lbs (5.2 kg)
DH-AP-5	Standard Plate	11.6 lbs (5.2 kg)
DH-AP-6	Plate for Inclined Surfaces with tie-off anchor	27.2 lbs (12.8kg)
DH-AP-7	Plate for Inclined Surfaces	27.2 lbs (12.8 kg)

Miller DH100 / DH200 / DH300 Series Digital Winches

DH100



Miller **DH100 / DH200 / DH300 Series Digital Winches** include a permanently mounted fold-away crank handle to the 9:1 hub drive with an average speed of 13 ft/min (4m/min). All Digital Series Winches are rated for a maximum working load of 450 lbs with an 11:1 safety factor. Available in 3 standard sizes, the 100, 200 and 300 Series winches hold up to 300 feet of 3/16 in. (5mm) diameter cable. All cable assemblies include a double locking swivel snap hook with overload indicator. An exclusive feature of the winch is the "digital usage indicator" system that counts the revolutions of the drum to determine service intervals. Additional standard features include braking system with 3 independent working pawls, centrifugal back-up brake, carrying handle and cable retainer spring.



Digital Usage Indicator

Miller 100/200/300 Series Digital Winch Packages

Model No.	Description	Weight
DH100/70ft	Miller 100 Series Digital Winch - c/w 70ft 3/16 in. stainless steel cable	30.5 lbs (13.8 kg)
DH100/100ft	Miller 100 Series Digital Winch - c/w 100ft 3/16in. stainless steel cable	32.5 lbs (4.7 kg)
DH200/150ft	Miller 200 Series Digital Winch - c/w 150ft 3/16 in. stainless steel cable	40 lbs (18.4 kg)
DH200/200ft	Miller 200 Series Digital Winch - c/w 200ft 3/16 in. stainless steel cable	43 lbs (19.5 kg)
DH300/250ft	Miller 300 Series Digital Winch - c/w 250ft 3/16 in. stainless steel cable	50 lbs (22.6 kg)
DH300/300ft	Miller 300 Series Digital Winch - c/w 300ft 3/16 in. stainless steel cable	53.5 lbs (19.5 kg)

Miller Basic Winch Packages

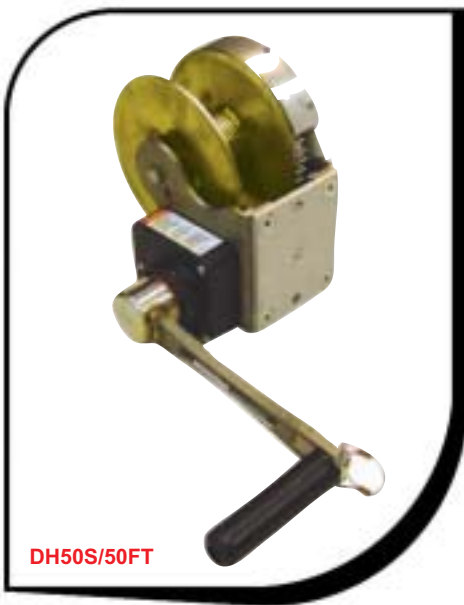

DH50S/50FT

The **Basic Series Winch** holds up to 50ft (15m) of 3/16 in. (5mm) diameter cable. Zinc-plated with a Load Limiter Clutch to indicate a fall or misuse. This unit requires annual re-certification by the manufacturer. The Basic Series Winch includes a permanently mounted handle to the 5.1:1 hub drive with an average speed of 30 ft/min (9m/min). The handle is durable, simple to use and features a foldaway crank.



DH50AS/50FT

Miller Basic Series Winch Packages

Model No.	Description	Weight
DH50S/50FT	Basic Winch w/50ft Stainless Steel Cable & Bolt-On Plate	22 lbs (10 kg)
DH50T/50FT	Basic Winch w/50ft Technora Rope & Bolt-On Plate	20 lbs (9 kg)
DH50AS/50FT	Basic Winch w/50ft Stainless Steel Cable & Quick Plate Adapter	22 lbs (10 kg)
DH50AT/50FT	Basic Winch w/50ft Technora Rope & Quick Plate Adapter	20 lbs (9 kg)

Miller Connecting Devices & Personal Fall Limiters



The **Miller MightEvac™ Self-Retracting Lifeline w/ Emergency Retrieval Hoist** is available with 50ft., 100ft. or 130ft. galvanized wire rope lifeline. Must be used for emergency evacuation only! The Miller MightEvac™ features corrosion-resistant stainless steel /aluminum components and promotes quick and easy rescue with a 4:1 mechanical advantage (average speed of 25ft. [7.6m] per minute). Includes a convenient, heavy-duty carrying handle. Maximum work load 310lbs. No annual factory recertification (USA only).

Model #	Description	Weight
MR50GB/50FT	MightEvac w/50ft Galvanized Wire Rope (3/16 in.) w/Mounting Bracket	39 lbs (17.6 kg)
MR50SB/50FT	MightEvac w/50ft Stainless Steel (3/16 in.) Cable w/Mounting Bracket	39 lbs (17.6 kg)
MR100GB/100FT	MightEvac w/100ft Galvanized Wire Rope (3/16 in.) w/Mounting Bracket	59 lbs (26.79 kg)
MR100SB/100FT	MightEvac w/100ft Stainless Steel (3/16 in.) Cable w/Mounting Bracket	59 lbs (26.79 kg)
MR130GB/130FT	MightEvac w/130ft Galvanized Wire Rope (3/16 in.) w/Mounting Bracket	64 lbs (29.02 kg)
MR130SB/130FT	MightEvac w/130ft Stainless Steel (3/16 in.) Cable w/Mounting Bracket	64 lbs (29.02 kg)



Miller Black Rhino™ Cable Self-Retracting Lifelines are constructed of lightweight, corrosion-resistant, stainless steel and aluminum components and feature 9ft. of stainless steel wire rope to endure the daily rigors of harsh environments. The Black Rhino's quick-activating, high-strength stainless steel braking system arrests free falls to provide a quick, safe rescue. The integral load indicator indicates when the unit must be removed from service and returned for repair. No annual factory recertification (USA only).

Model #	Description	Weight
CFL-2/9FT	Black Rhino™ Lifeline w/Steel Twist Lock Carabineer	4.8 lbs (2.17 kg)
CFL-4/9FT	Black Rhino™ Lifeline w/Stainless Steel Swivel & Steel Twist-lock Carabineer.	5 lbs (2.26 kg)



The 9ft. web **Miller Scorpion™ Personal Fall Limiter** is an affordable alternative to shock-absorbing lanyards. Lightweight, compact design boasts a quick-activating, high-strength stainless steel braking system for arresting free falls and provides a quick, safe rescue. The visual load indicator indicates when the unit must be removed from service (*no annual factory recertification required*). The Scorpion PFL is intended for dual operations - it can be attached directly to a harness back D-ring or can be used as a traditional retractable lifeline.

Model #	Description	Weight
PFL-4/9FT	Miller Scorpion™ w/Carabineer & Swivel Shackle	3 lbs (1.36 kg)
PFL-16/9FT	Miller Scorpion™ w/Steel Twist Lock Carabineer & Swivel Saphook	3 lbs (1.36 kg)



The compact 11ft. web **Miller MiniLite® Fall Limiter** has a maximum work load of 310 lbs and is a self-retracting web lanyard with quick activating brake system that's designed to limit free falls. Corrosion-resistant, stainless steel interior components are combined with high-impact thermoplastic housing, making the MiniLite® Fall Limiter ideal for general plant maintenance, aerial or fork lifts, cherry pickers, bucket trucks, scaffold and steel erection applications. The visual load indicator identifies when a unit has been involved in a fall. Webbing is protected with Teflon® HT for up to 25% longer service life.

Model #	Description	Weight
FL11-3/11FT	Miller MiniLite® Fall Limiter w/Carabineer & Swivel Shackle	2.6 lbs (1.79 kg)

Miller DuraHoist Brackets, Carts & Accessories



The **Miller Advanced Series Winch Mount Bracket** is designed to mount Miller Basic and Digital Winches and self retracting lifelines. Adapter plates are available to fit other manufacturers' winch and self retracting lifeline models.

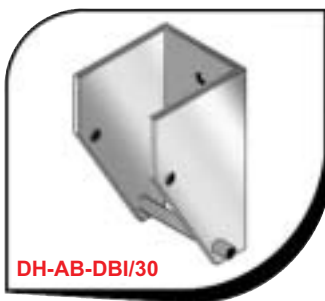

The **Miller Thirty Degree Inclined DBI Style Adapter Bracket** is a flat-back adapter bracket designed to secure to the front side of the DH-3 One Piece Adjustable Mast. Requires the use of the DH-19 *Miller Advanced Series Winch Mount Bracket*.



The **Flat Back Adapter Bracket for Miller MightEvac 3-Way SRL** is designed to mount the Miller MightEvac to the DuraHoist System or the Portable Fall Arrest Anchor Post davit, DH-AP-3.



The **Miller Flat Back Adapter Bracket for DBI Style Winches/SRLs** is designed to mount to the Miller DH-19 or directly to the DH-AP-3.



The **Flat Quick Mount Bracket** is designed to allow the winch to be removed from the bracket with ease.

Miller DuraHoist Brackets & Adapters		
Model #	Description	Weight
DH-19	Winch Mount Bracket	1.6 lbs (0.7 kg)
DH-AB-MILLER	Adapter Bracket for Miller MightEvac	1.5 lbs (0.7 kg)
DH-AB-DBI	Adapter Bracket for DBI Winch	2 lbs (0.9 kg)
DH-AB-DBI/30	Adapter Bracket for DBI Winch (30 Degree Incline)	2 lbs (0.9 kg)
DH-AP-8	Flat Quick Mount Bracket	2.5 lbs (1.1 kg)

DuraHoist Equipment Cart
Transport the DuraHoist System with maximum ease over smooth or rough terrain.

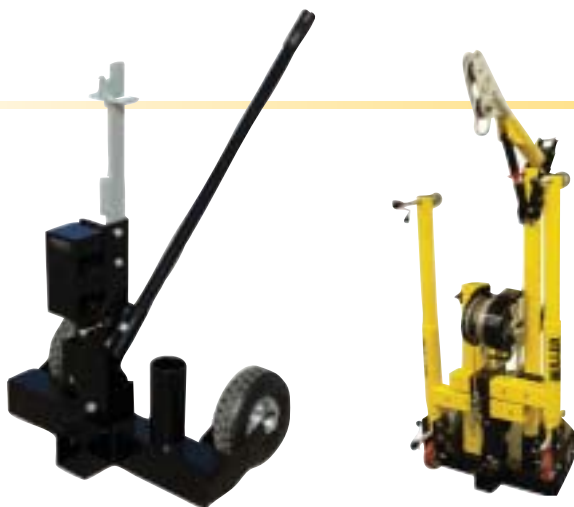

Carts & Accessories



Wheel Kit for Three Piece Bases This optional wheel kit attaches quick and easy, allowing you the freedom to move the DuraHoist system from entry to entry without having to disassemble it.

DH4-WK

Miller DuraHoist Carts & Accessories		
Model #	Description	Weight
DH-18	DuraHoist Equipment Cart	40 lbs (8.9 kg)
DH-18DC	Dust Cover for the DuraHoist Equipment Cart (DH-18)	2 lbs (0.9 kg)
DH4-WK	Wheel Kit for the Three Piece Base (DH-4)	30 lbs (13.6 kg)

Miller DuraHoist Carrying Bags



DH-AP-2BAG



DH-AP-1-3BAG



DH-2BAG



DH-4BAG

Miller Carrying Bags are available to protect and transport the DuraHoist or Portable Fall-Arrest Anchor Post. Constructed from heavy duty materials with rugged zippers, padded side panels and adjustable carrying straps. These bags will protect the investment for many years. Available in black only.

Miller DuraHoist Carrying Bags

Model No.	Description	Weight
DH-AP-2BAG	Carrying Bag for 14" Extension Post (DH-AP-2)	.5 lbs (.22 kg)
DH-AP-1-3BAG	Carrying Bag for Portable Fall-Arrest Anchor Post & Davit Arm (DH-AP-1 & DH-AP-3)	5 lbs (2.26 kg)
DH-2BAG	Set of two Carrying Bags for the DuraHoist Four Piece Hoist System (DH-2)	11 lbs (4.98 kg)
DH-4BAG	Carrying Bag for the Three Piece Base (DH-4)	5 lbs (2.26 kg)

Miller Tripods & Series 70 Accessories



51X/9FT

Miller Tripod

- 7ft. or 9ft. tripod models available
- Lightweight, high-strength aluminum construction
- Adjustable legs
- Safety chain; rubber skid pads/serrated edge tripod feet

Miller Series 70 Universal Rescue System

- Lightweight, compact, versatile access and retrieval rope system
- Simple, one or two-person operation
- Aluminum head assembly with roller pulley and anti-reversing lock
- Kernmantle rope with tensile strength of 5600lbs. and high temperature resistance to 360°F
- Rope control handle with friction locking device and with permanently attached Manyard shock-absorbing lanyard



70-100/100FT



Miller Tripod & Series 70 Systems

Model No.	Description	Weight
51/7FT	Seven Foot (2M) High Strength Aluminum Tripod	42.0 lbs (19.05 kg)
51X/9FT	Nine Foot (2.7M) High Strength Aluminum Tripod	53.0 lbs (24.04 kg)
70-100/100FT	Series 70 System w/25ft Working Length Rope	19.5 lbs (8.84 kg)
70-200/200FT	Series 70 System w/50ft Working Length Rope	23.5 lbs (10.6 kg)
70-400/400FT	Series 70 System w/100ft Working Length Rope	31.0 lbs (14.06 kg)
70-500/500FT	Series 70 System w/125ft Working Length Rope	34.75 lbs (15.7 kg)
70-C	Rope Control Handle w/attached Manyard Absorbing Lanyard	3.0 lbs (1.3 kg)

Miller Harnesses & Lanyards

DURAFLEX Python HARNESS



P950FDQC/UGNU

DuraFlex Python® Ultra Harnesses are made with cushioned tubular webbing in the shoulder straps to minimize discomfort around neck & shoulders when wearing a tool belt. Includes patented DuraFlex® stretchable webbing in the lower torso for greater comfort, safety and productivity. Front D-ring. Features sleek, quick-connect buckles on the chest and leg straps for easy donning; specially-woven, breathable, comfort-touch back D-ring pad for greater comfort and tangle-free donning. Webbing protected with Teflon® HT for up to 25% longer service life. Includes friction buckle shoulder straps and belt loops to accommodate a tool belt. Rated to 400lbs. capacity. Available in high visibility Lime Green or greater chemical resistant Blue webbing; Universal size fits most.



P950FD-4/UGNU

Miller **DuraFlex Python™ Harnesses** feature wrap-around comfort with cushioned tubular webbing shoulder straps that reduces neck irritation and shoulder stress when wearing a tool belt. Specially-formulated DuraFlex stretch webbing torso straps move with the body for greater flexibility, mobility and less fatigue. Front D-ring; Tongue buckle leg straps. Webbing protected with Teflon® HT for up to 25% longer service life. Rated to 400lbs capacity. Available in high visibility Lime Green or greater chemical resistant Blue webbing; Universal size fits most.



850T-3/UGKU

Miller **HP™ (High Performance) Non-Stretch Harnesses** Webbing protected with Teflon® HT for up to 25% longer service life. Comfort-touch back D-ring pad for greater comfort. Bright colors for high visibility. Pull-free lanyard rings for lanyard attachment when not in use. Available in Lime Green or greater chemical resistant Blue webbing. Universal size fits most.



216M/6FTGN

Miller Manyard® II Shock-Absorbing Lanyards Six ft. web tubular lanyards with w/ a built-in shock-absorbing inner core that smoothly expands up to 42 inches to safely reduce fall forces. Heavy duty tubular web outer jacket serves as a back-up lanyard for added safety. Unique warning flag indicates unit has been involved in a fall and should be removed from service. Available in lengths from 4ft. to 10ft.



216TWLS/6FTGN

Miller Manyard® HP™ (High Performance) Shock-Absorbing Lanyards Six ft. web tubular lanyards with w/ a built-in shock-absorbing inner core that smoothly expands up to 42 inches to safely reduce fall arrest forces. Heavy duty tubular web outer jacket serves as a back-up lanyard for added safety. Unique warning flag indicates unit has been involved in a fall and should be removed from service. Webbing protected with Teflon® HT for up to 25% longer service life. Maximum work load 310lbs. Available in high visibility Lime Green or greater chemical resistant Blue webbing. Available in lengths from 4ft. to 10ft.



913B/6FTGN

Miller BackBiter® Tie-Back Lanyards w/ SofStop® Shock Absorbers All-in-one 6 ft. lanyard with SofStop® shock absorber and cross-arm anchorage connector. Unique Miller 5K® snap hook with 5,000lbs. gate load capacity from any angle for greater safety. Heavy-duty webbing with 5-times more abrasion resistance. The SofStop® shock absorber pack is designed w/ a special woven inner core that smoothly expands up to 42 inches to safely reduce fall arrest forces. Heavy duty tubular web outer jacket serves as a back-up lanyard for added safety. Webbing protected with Teflon® HT for up to 25% longer service life. Available in high visibility Lime Green or greater chemical resistant Blue webbing.



8798T/6FTGN

Miller HP™ (High Performance) Lanyards w/ SofStop® Shock Absorbers Six ft. web lanyard w/SofStop shock absorber pack. Webbing protected with Teflon® HT for up to 25% longer service life. The SofStop pack is designed w/ a special woven inner core that smoothly expands up to 42 inches to safely reduce fall arrest forces. Heavy duty tubular web outer jacket serves as a back-up lanyard for added safety. Maximum work load 310lbs. Available in high visibility Lime Green or greater chemical resistant Blue webbing.

Miller DuraHoist Harnesses & Lanyards

Model #	Description	Weight
850T-3/UGKU	Universal Size Harness, Sliding Back D-Ring, Shoulder D-Ring, Mating Buckle Chest & Leg Strap	2.90 lbs (1.31 kg)
850TFD/UGKU	Universal Size Harness, Sliding Back D-Ring, Vest-Style Front D-Ring, Mating Buckle Chest & Leg Strap	2.80 lbs (1.27 kg)
P950FD-4/UGNU	Universal Size Harness, Sliding Back D-Ring, Tongue Buckle Leg Strap, Mating Buckle Chest Strap	3.50 lbs (1.58 kg)
P950FDQC/UGNU	Universal Size Harness, Vest-Style Front D-Rings, w/Quick-Connect Buckle Leg & Chest Straps	3.85 lbs (1.7 kg)
216M/6FTGN	Six Foot Stretch Tubular Shock Absorbing Lanyard. Expands from 4 to 6 feet w/Teflon® HT Protection	2.08 lbs (0.94 kg)
216TWLS/6FTGN	Six Foot Tubular Shock Absorbing Lanyard w/Teflon® HT Protection	1.75 lbs (0.79 kg)
8798T/6FTGN	Double Legged, 6 Foot Shock Absorbing Lanyard SofStop® Pack w/Teflon® HT Protection	3.00 lbs (1.3 kg)
913B/6FTGN	Six Foot, Tie-Back Shock Absorbing Lanyard with 5K Snap Hook w/Teflon® HT Protection	2.80 lbs (1.2 kg)



Toll Free 800/873-5242 Fax 800/892-4078
Phone 814/432-2118 Fax 814/432-2415

For more information or to place an order, please contact your Miller distributor.