

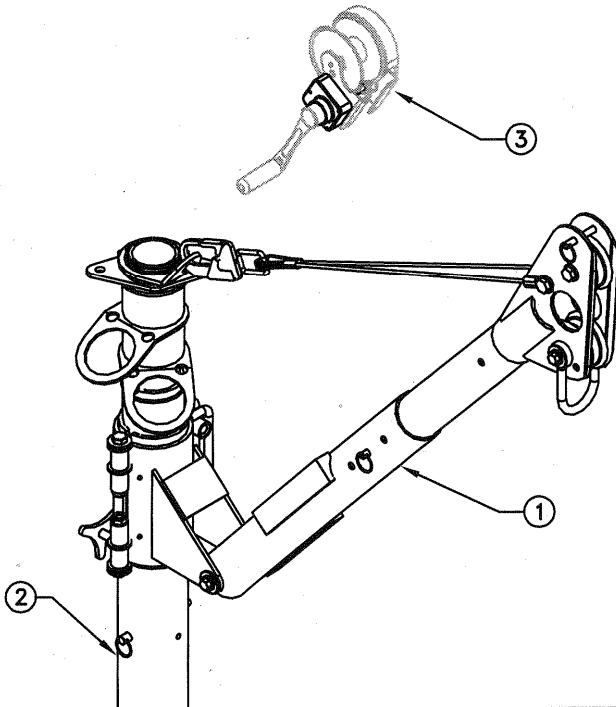

Model DH-AP-3 includes the following

Item	Part no.	Description
1	DH-AP-3	MILLER DURAHOIST Portable Fall-Arrest Anchor Post Davit Arm Assembly
accessories shown, but not included		
2	DH-AP-1	MILLER DURAHOIST PFAS Anchor Post
3	---	Typical Winch/SRL w/ Appropriate Mounting Bracket



DESCRIPTION

The MILLER DURAHOIST Anchor Post Davit Arm attaches quickly, without the use of any tools, to the Portable Fall-Arrest System Anchor Post. Fitted with a suitable winch or self retracting lifeline, the Davit Arm can be used for a wide variety of access/egress, rescue, and material handling applications. Lightweight aluminum construction and durable powdercoat finish.

General Specifications:

Working Load	
Material Handling	310 lb (141 kg)
Safety Factor	10:1
Rescue	310 lb (141 kg)
Safety Factor	10:1
Proof Load	
Outer Anchor Point	3100 lbs (13.8 kN)
Winch/SRL Bracket	3100 lbs (13.8 kN)
Maximum Allowed Arrest Force (MAF) Rating of Shock Absorbers and Retractable Devices	900 lbs (4 kN)
Test Numbers	UCT-357, 358, 359, 360, 361, 376, 378, 397, 398, 399, 400
Weight	20.5 lbs(9.3 kg)

Materials & Construction:

General Construction	Welded/Machined Aluminum
Weld Certification	CWB-47.1, CWB-47.2
Material (aluminum)	6061-T6 Aluminum
Cable	3/16" 7 X 19 Stainless Steel
Pully Wheel	Black Acetal
Finish(Aluminum Parts)	Powder Coat
Finish(Steel Parts)	CS-500 Zinc Plate
Bearing Material	PVC Pipe, ASTM-D-1785
Hardware	Minimum Grade 5, Zinc Plated
Plating Specification	ASTM Designation B633-85, Type II SC2, CS-500 Leachant/Sealant Process

Application Restrictions

1. This device is to be used with the MILLER DURAHOIST Portable Fall-Arrest System Anchor Post **ONLY**.
2. Use of this device de-rates the Anchor post to a maximum of two(2) workers tie-off to the swivel tie-off rings.
3. The installed Anchor Post **MUST BE** 72" (1830mm) or less from any edge where a fall may occur.
4. Portable Fall-Arrest System Anchor Post **MUST BE** in a vertical position any time it is being used as a fall-arrest anchor post.
5. Retractable devices and shock absorbers **MUST HAVE** a maximum arrest force (M.A.F.) rating of 900 lbs. (4kN) or less, and **MUST BE** installed and used in accordance with the manufacturer's instructions.
6. Each installation **MUST BE** approved to local standards by a qualified engineer.

Certification



MILLER DURAHOIST PORTABLE
FALL-ARREST ANCHOR POST DAVIT ARM
ASSEMBLY MODEL: DH-AP-3

SPECIFICATIONS
PAGE 2 of 2

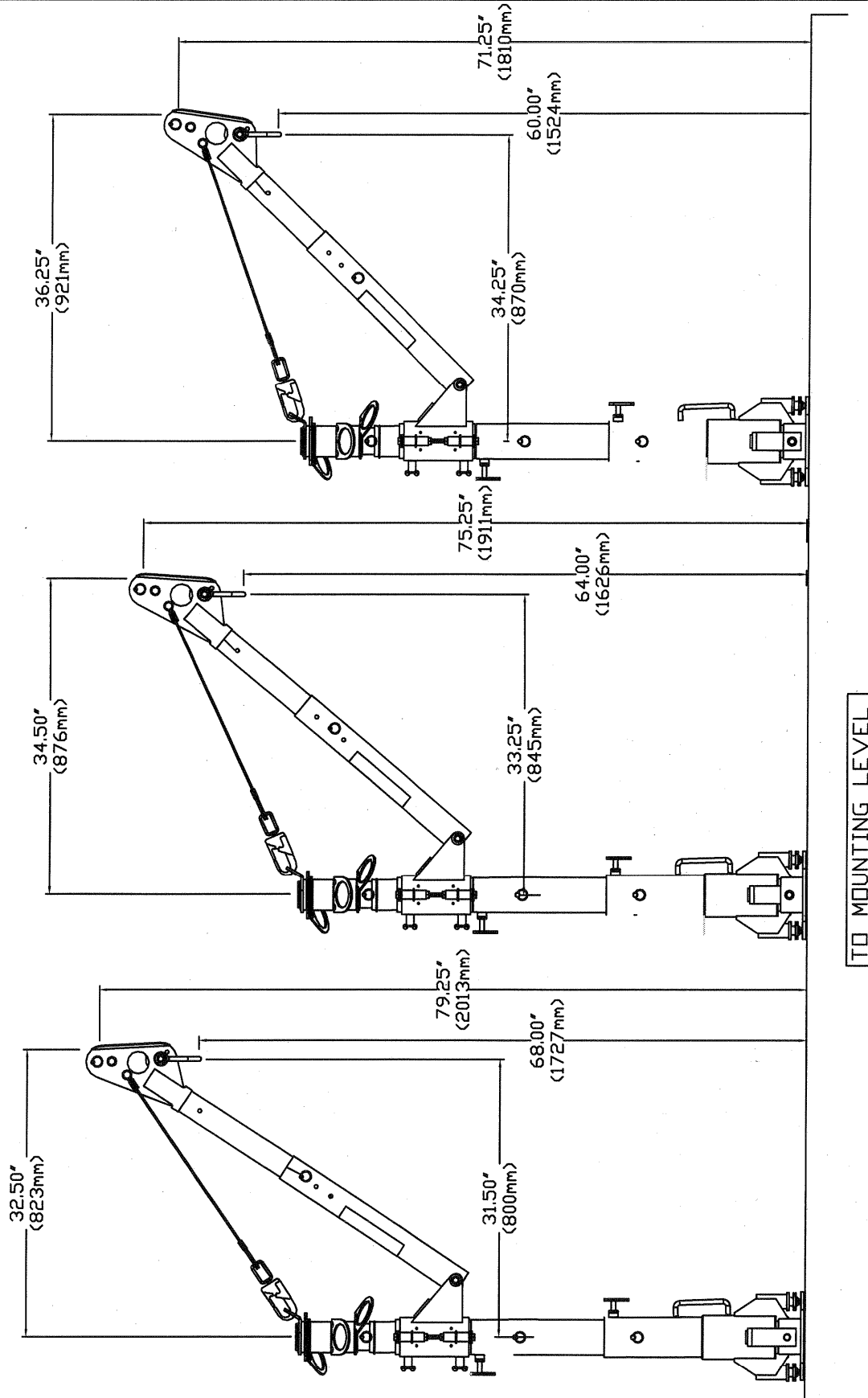

DALLOZ FALL PROTECTION, 1345 15th Street, Franklin, PA, USA 16323
Phone: (814) 432-2118 Fax: (814) 437-2973, www.bacou-dalloz.com